



ACM-4200

Megapixel IP Cube Camera



* The bracket is included.

- 1/3" Micron Progressive Scan CMOS
- Bundled with f4.2mm / F1.8 Megapixel lens
- 0.5 Lux at F1.8
- Shutter Speed, White Balance, Exposure, Gain Controls
- Selectable MPEG-4 / MJPEG compression
- Up to SXGA resolution at 8 FPS
- Multi-stream with variable frame rate in the same compression
- Two-way audio supported
- Hardware motion detection



- 1 Power LED Indicator
- 2 Built-in Microphone

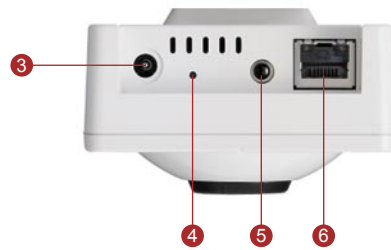

- 3 DC 3.3 V Power Input
- 4 Reset Button
- 5 Audio Output
- 6 Ethernet Port

DIMENSION DIAGRAM

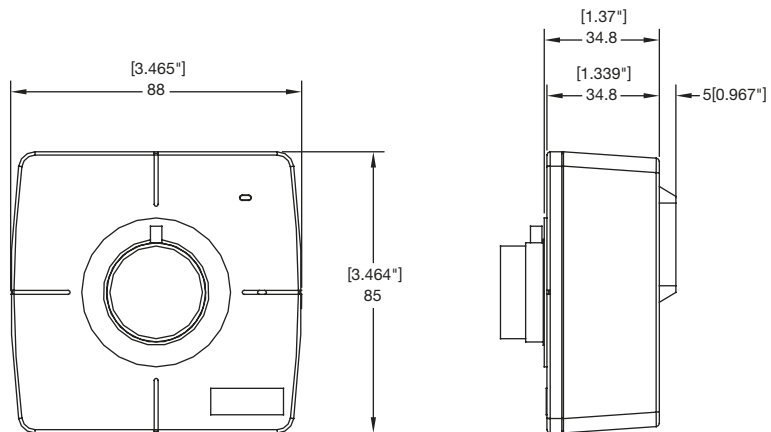

Unit: mm [inch]

**PRODUCT SPECIFICATION**

		ACM-4200
Image	Device	Micron Progressive Scan CMOS
	Size	1/3 inch
	Effective Pixels	1280 x 1024
Min. Scene Illumination	Color	0.5 Lux at F1.8 (30 IRE,MAX AGC)
Lens	Lens	f 4.2 mm / F1.8
	Viewing Angle	75° (Horizontal)
Synchronization	Sync. System	Internal
Functions	Motion Detection	Yes (3 windows)
	Electronic shutter	1/10 ~ 1/2,000 sec. (60 Hz) 1/10 ~ 1/2,000 sec. (50 Hz)
	Flickerless	1/120 sec. (60 Hz) 1/100 sec. (50 Hz)
	BLC	Yes
	AGC	Automatic (User defined)
	White Balance	6 modes (AUTO, INDOOR1, INDOOR2, OUTDOOR1, OUTDOOR2, HOLD CURRENT, MANUAL) configurable
S/N Ratio	S/N Ratio	Better than 44 dB
Video Compression	Compression	MPEG-4 SP / MJPEG
	Picture Resolution	SXGA (1280x1024) HD 720 (1280x720) VGA (640x480)
	Image Frame Rate	8 fps at SXGA 10 fps at HD720 30 fps at VGA
Audio Input	Compression	8 kHz, Mono, PCM
	Built-in Microphone	Sensitivity: -36±3dB(0dB=1V/Pa); S/N Ratio: more than 58 dB; Directivity: Omni-directional
Audio Output	Compression	8 kHz, Mono, PCM
	Audio Line Output	Unbalanced, 1.4Vp-p, 1Vrms, 3.5 mm Phone Jack
External I/O	Reset Button	Factory default
	LED	System status
Network	Ethernet	Ethernet(10/100 Base-T), RJ-45 connector
	Protocol	TCP, UDP, IP, HTTP, DHCP, PPPoE, RTP, RTSP, FTP, SMTP, DNS, DDNS, NTP, ICMP, IGMP, ARP, 3GPP
Software	Web Browser	Microsoft Internet Explorer 6.0 or above
	SDK	ACTi SDK-10000
	Security	Password protection: configured by the administrator
Operating	Temperature	0 °C ~ 40 °C (32 °F ~ 104 °F)
Power	Power Requirement	DC 3.3 V ±10%
	Power Consumption	2.4 W
Physical	Dimensions (WxHxD)	88 mm x 85 mm x 52.1 mm (3.46" x 3.35" x 2.05")
	Weight	150 g (0.33 lb), w/o bracket

ORDERING INFORMATION

Model Name	Description
ACM-4200	Megapixel IP Cube Camera

ACCESSORY OPTIONS

• Lens, f4.5~10mm F1.6, C mount, Format 1/2"	LEN-104
• Lens, f2.4~6mm F1.2, CS mount, Format 1/3"	LEN-201
• Lens, f2.8~12mm F1.3, CS mount, Format 1/3"	LEN-202

Bundled Accessory

- Max. Load: 1.5 kg
- Material / Color: ABS PLASTIC / Grey
- Dimension (H x D) : 115 mm X 80 mm
- Swivel Angle: 360°
- Tilt Angle: 90°