



Lens : optional

## BROADBAND CAPABLE: ONE NETWORK CAMERA FOR 24-HOUR SURVEILLANCE

New from Panasonic, the WV-NP472 directly connects to either digital or analogue devices. Simply set an IP address and connect it to an **Ethernet terminal** for monitoring and control from a personal computer.

Or use the analogue video out to connect to conventional monitoring systems using coaxial cable.

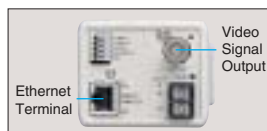

The WV-NP472 camera utilizes Panasonic's **Super Dynamic II** function to capture natural images at entryways, near windows, and in other locations with harsh contrasts between light and dark. It automatically stores images in repose to inputs from motion detectors and external sensor alarms and can send images automatically as e-mail attachments. In addition, this colour camera can also control external devices, turning on lighting or starting a surveillance recorder working. It operates with only 0.8 lux of available light in colour mode and a mere 0.1 lux in black and white. Its **Day/Night switching** function automatically switches to black-and-white recording when available light is low. Thus, this single security camera can deliver 24-hour surveillance.

The WV-NP472 is designed for monitoring over a WAN or over the Internet a snap. Its sophisticated surveillance functions make this the network security camera of choice for a wide range of settings, including banks, office buildings, and franchise outlets.

### KEY FEATURES

- 1/3-type double speed CCD colour image sensor.
- Built-in network interface (10Base-T/100Base-TX) for remote monitoring by PC.
- Interface protocol ; TCP/IP, HTTP, FTP, SMTP, DNS and DHCP.
- Switches from selected colour mode to B/W mode automatically or manually, for 24-hour monitoring.
- Built-in **Super Dynamic II** function has 80 times wider dynamic range when compared to a conventional camera.
- High sensitivity of,
  - 0.8 lux in colour, 0.1 lux in B/W mode, at F1.4 optional lens
  - 0.6 lux in colour, 0.75 lux in B/W mode, at F1.2 optional lens
- 480-line in colour mode, and 570-line in B/W mode horizontal resolution.
- Built-in Alarm function for external security devices, and FTP alarm activation.
- Built-in digital motion detector.
- Built-in 16 alphanumeric character display.
- Electronic sensitivity enhancement (Auto; up to 10x, Manual; up to 32x, and Off)
- Digital signal processing LSI's for high quality pictures.
  - 2H vertical enhancement for greater picture sharpness.
  - Chroma averaging circuit for better colour signal-to-noise ratio.
  - Minimum of aliasing on fine objects.
  - Expanded dynamic range by knee circuit.
  - Highlight aperture correction for greater picture details of bright objects.
- VD2 sync capability with Panasonic system products.
- DC 12V power supply for easy installation.

### WIDE VARIETY OF OPTIONAL LENSES

Auto Iris Lenses WV-LA2R8C3B WV-LA4R5C3B WV-LA9C3B	Zoom Lens WV-LZ61/15 (x15)	Variable Focal Lenses WV-LZA61/2S WV-LZF61/2 WV-LZ62/8S

## SYSTEM EXAMPLES

### 1 Monitoring System utilizing an Intranet

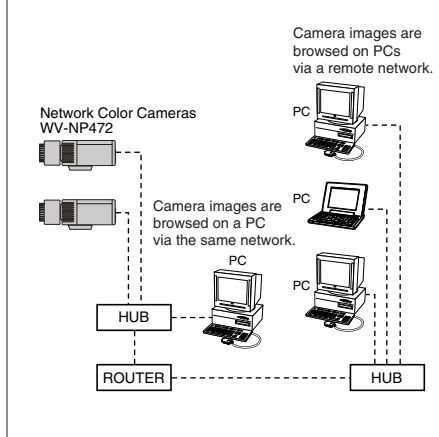

### 2 Monitoring with Panasonic Matrix Systems

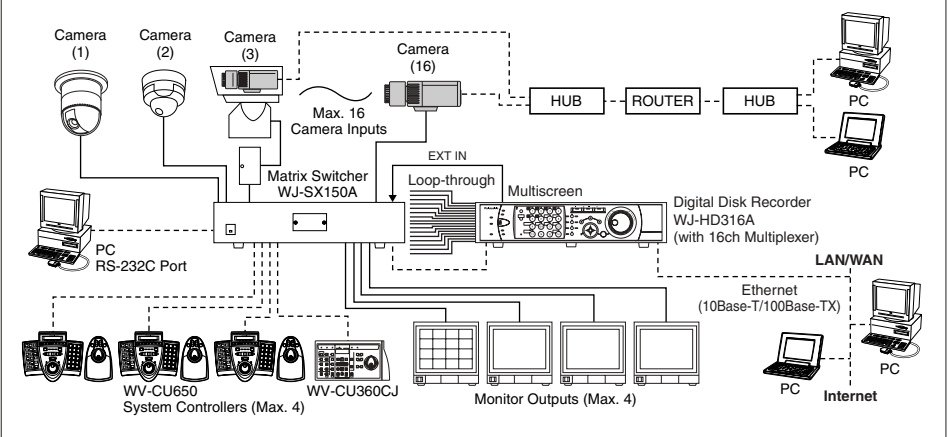

## SPECIFICATIONS PAL CCIR

General	
Ambient Operating Temperature	-10°C - +50°C
Ambient Operating Humidity	Less than 90%
Power Source and Power Consumption	12V DC, 700mA
Dimensions (without lens)	70 (W) x 65 (H) x 118 (D) mm
Weight (without lens)	510 g
Network Section	
Image Resolution	752 x 568, 752 x 280, 368 x 280, 176 x 136 pixels
Image Process	JPEG / MJPEG
Image Refreshing Rate	Fast/Middle/Slow/Very Slow
Traffic Control	32 kbps, 64 kbps, 128 kbps, 256 kbps, 512 kbps, 1,024 kbps, Unlimited
Protocol Supported	TCP/IP, HTTP, FTP, SMTP, DHCP, and DNS
OS Applicable	Windows98 SE, Windows NT 4.0, Windows2000, Windows ME, or Windows XP
Browser Applicable	Internet Explorer 5.01 SP2, 5.5, 5.5 SP2, 6.0 or Netscape Communicator 4.73, 4.78
Camera Section	
Pick-up Device	753 (H) x 582 (V) pixels, Interline Transfer CCD
Scanning Area	4.8 (H) x 3.6 (V) mm (Equivalent to scanning area 1/3" pick-up tube)
Scanning	625 line/50 fields/25 frames
Horizontal	15.625 kHz
Vertical	50 Hz
Synchronization	Internal, or Multiplexed Vertical Drive (VD2)
Video Output	1.0V[p-p] PAL/CCIR composite 75Ω/BNC connector
Horizontal Resolution	480 lines at colour, 570 lines at B/W mode
Signal-to-Noise Ratio	50dB (Equivalent to AGC Off, Weight On)
Dynamic Range	46dB
Minimum Illumination	0.8 lux in colour, 0.1 lux in B/W mode, at F1.4 optional lens 0.6 lux in colour, 0.75 lux in B/W mode, at F1.2 optional lens
Gain Control	ON (DNR-H), ON (DNR-L) or OFF (SET UP MENU) selectable
White Balance	ATW1, ATW2 or AWC (SET UP MENU) selectable
Aperture	Set Variable (SET UP MENU)
Sense Up	OFF, AUTO (x2, x4, x6, x10), FIX (x2, x4, x6, x10, x16, x32)
Super Dynamic II	ON or OFF (SET UP MENU) selectable
Electronic Light Control	1/50 (OFF), 1/120, 1/250, 1/500, 1/1,000, 1/2,000, 1/4,000, 1/10,000 s selectable
Lens Mount	CS-mount
ALC Lens	DC or Video selectable
Control Terminal	Alarm In: Pulled-up to 3.3V DC, OFF (Open or 2V DC - 12V DC) / ON (0V 0.4mA) Alarm Out: Collector-output, OFF (Open or 4V DC - 5V DC) / ON (≤1V 50mA) Pulse/ Latch selectable Auxiliary Out: Collector-output, OFF (Open or 4V DC - 5V DC) / ON (≤1V 50mA) Day/Night In: Pulled-up to 5V DC, OFF (Open) / ON (0V 0.2mA)

## Frame Rate Chart

Image Resolution	Mode	Super Fine (1/6)			Fine (1/8)			Normal (1/10)			Extended (1/12)		
		Mbps	kB	ips	Mbps	kB	ips	Mbps	kB	ips	Mbps	kB	ips
752 x 568 (frame)	JPEG	4.0	100	5	3.9	69	7	3.6	56	8	3.7	52	9
	MJPEG	5.6	100	7	5.5	69	10	5.4	56	12	5.0	52	12
752 x 280 (field)	JPEG	2.6	46	7	2.5	35	9	2.1	29	9	1.9	26	9
	MJPEG	5.5	46	15	5.9	35	21	5.8	29	25	5.2	26	25
368 x 280 (field)	JPEG	2.9	23	16	2.4	18	17	2.5	15	21	2.5	15	21
	MJPEG	4.6	23	25	3.6	18	25	3.4	15	25	3.0	15	25
176 x 136 (field)	JPEG	2.6	20	16	2.7	16	21	2.2	13	21	2.2	12	23
	MJPEG	4.0	20	25	3.2	16	25	2.6	13	25	2.4	12	25

**Important** – Safety Precaution: carefully read the operating instructions and installation manual before using this product.

– Panasonic can not be responsible for network performance and/or other manufacturer products that reside on the network.

• Weights and dimensions are approximate. • Specifications are subject to change without notice. • These products may be subject to export control regulations.

DISTRIBUTED BY:

## MAJOR OPERATING CONTROLS

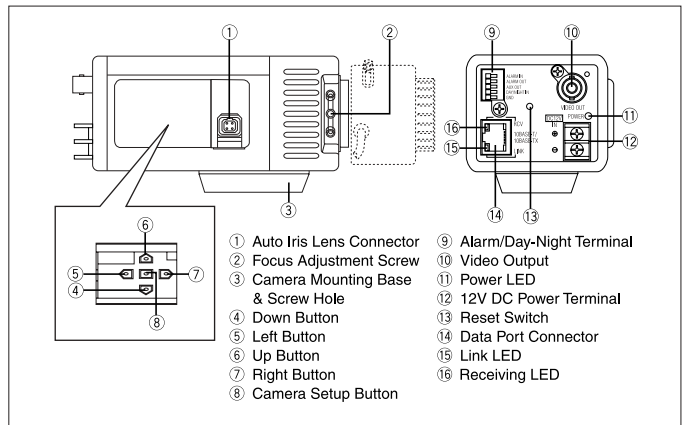

## APPEARANCE

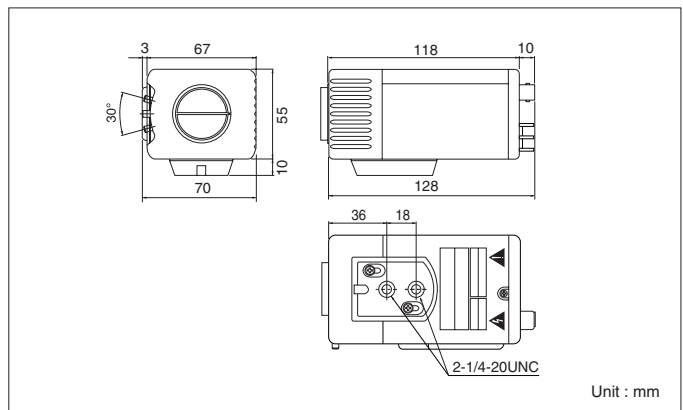

## OPTIONAL COMPONENTS

DIGITAL DISK RECORDERS	MATRIX SYSTEMS
<b>WJ-HD316A</b> (with 16ch Multiplexer) <b>WJ-HD309A</b> (with 9ch Multiplexer) <b>WJ-HD220</b> (with 8ch Multiplexer)	<b>SYSTEM850</b> <b>SYSTEM500</b> <b>SYSTEM150</b>

# Panasonic

Panasonic is the brandname of Matsushita Electric.

Printed in Japan

WV-JKNP472T(2N-701E)